



# Quest Travel Network Compensation Plan Overview

The Quest Travel Network utilizes a compensation plan with an **E.D.G.E.** It is designed to pay YOU **Early**, and help YOU reach your **Dreams**, and reward **Growth** with a simple and **Easy** product and the “Just get 2” formula.

## How to Earn Commissions:

- Activate your Profit Center with one-time \$50
- Become a QIR (Qualified Independent Rep)
- Earn up to \$100 in Direct Sale Commissions
- Become an active Quest Travel Advisor (QTA) and make 2 product sales at this level to be eligible for bonuses

## “Just Get Two” Formula for Success:

- Easy to build a team and make massive direct sale and huge residual income
- Once you are a QTA, simply enrol 2 others that do the same and watch your Team grow quickly
- Those 2 create the start of the dual team bonus – One on your left and one on your right teams.

After you have personally enrolled your first two QTA’s, you are now a Silver Travel Advisor within the Leadership Titles of Quest Travel Network. As long as you maintain this Title, you are eligible to earn multiple Bonuses as part of this lucrative Commission Plan.

**Fast Start Bonus** – Qualify your way to a Silver Travel Advisor within 30 days from your date of enrolment and earn a \$100 Fast Start Bonus.

Over and above the Direct Sales Commissions and the Fast-Start Bonus, QTN pays the following Team Building bonuses through both a Uni-level structure and a Dual Team (binary) structure.

## The two Uni-level types of bonuses are:

**Title Bonus (coded bonus)**

**Activity Bonus (monthly residual bonus)**

### Title Bonus

- When a person joins Quest Travel Network as a Representative, the new Representative is immediately coded to the Enroller and the 1<sup>st</sup> upline, qualified and eligible to earn coded bonuses – 5 Leadership levels deep, in up to \$10 intervals.
- As you advance in rank, you will earn these Team Title **bonuses of up to \$50** for the new enrolments that occur throughout your organization. You’ll be paid the difference between the title you are at and the next title below you - **Infinite Levels Deep!**

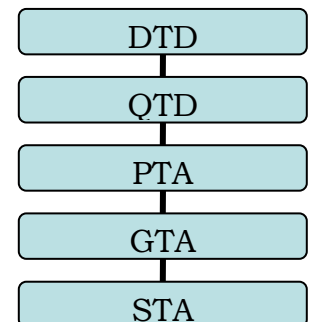

**Activity Bonus**

- ◆ Earned from the CondoQuest and Quest Travel Advisor Independent rep monthly membership fees. CondoQuest IR membership and QTA IR membership pays \$3/month.
- ◆ Earned on 6 Leadership Levels down unlimited depth.
- ◆ Based on the “Enroller” or “lineage structure” as of the last day of the monthly commission period.
- ◆ These bonuses are paid on a monthly basis, based on the active members within your lineage.

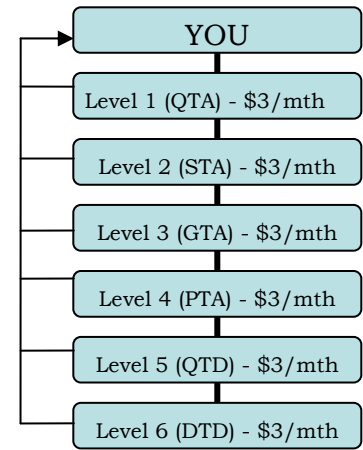

**Dual Team Bonus** – Our revolutionary 1/3, 2/3 NON FLUSHING Dual Team Binary makes this bonus the most powerful in the Industry. There are three ways you can earn a Dual Team Bonus of \$75. Every time your Dual Team “cycles” with at least two QTA’s on either side, you earn a \$75 Dual Team Bonus. Any unused volume is carried forward into the next commission week NOT flushed out (or removed) on a regular basis!

**STANDARD BUSINESS PLAN**

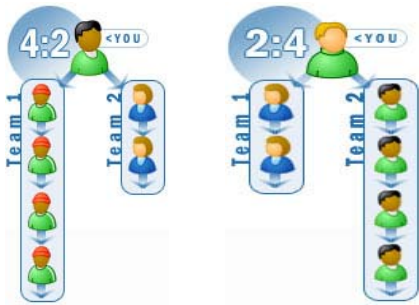

A cycle is paid on the “weak” leg and can occur and be paid by accumulating a minimum of 40 QV on the “weak Leg” and a total of 120 QV combined. So, a cycle can occur with a 1/3, 2/3 split(illustrated to the left) or any volume in between up to 50-50(illustrated to the right).

**Cycle = \$75**

**EXECUTIVE BUSINESS PLAN**

Left Leg Team                      Right Leg Team

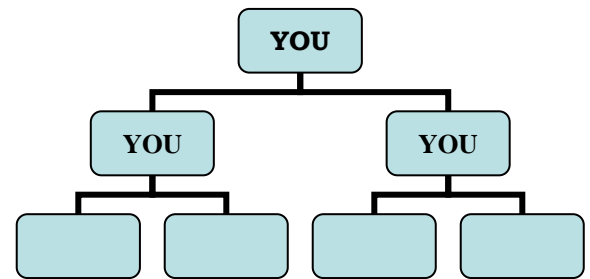

**Cycle = \$75**

**Matching Dual Team Bonus** – As a limited time promotion, we will match 50% of the cycle bonuses eligible to be paid based on your Leadership Title once you have achieved at least 5 cycles in any commission Dual Team commission period (week). That brings the total Dual Team Bonus to \$112.50.

**Dream Car Bonus** – Let QTN pay for that Mercedes Benz you have always wanted. The Dream Car Bonus works in conjunction with the Dual Team Bonus. As your team continues to grow, the number of cycles that will occur within your Dual Team will increase. Once you reach 40 cycles within a commission week, this bonus accrues until you reach the Diamond Travel Director Level then we pay for the car.



**Diamond Travel Director Bonus Pool** – 1% of the entire company’s business volume is placed in the DTD bonus pool. You earn “shares” in the pool by 1) becoming a DTD yourself and 2) develop other DTD’s within your Team.

**Travel Rewards** – The Travel Rewards program also works in conjunction with the Dual Team Bonus cycles. Every time your Dual Team cycles, you earn 5 Travel Rewards points that you can apply to your travel upon your return.

**Travel Commissions** – As an active QTA Member, you will have your own commissionable Travel Center that will pay you up to 50% of the Travel Agents commissions on all travel booked through the site.

# Leadership has It's Privileges!

Once qualified, Quest Travel Network's Leadership performance and bonus program is designed to reward you big for demonstrating Leadership skills and building your Team!

## Platinum Travel Advisor

### Qualifications and Retention

- ✦ Be an Active QTA
- ✦ Have 3 Active GTA legs
- ✦ Have at least 8 active personally enrolled reps – 1 left and 1 right

### Eligible Commissions

- ✦ Direct sale commissions
- ✦ Fast Start Bonus
- ✦ Dual Team Bonus (max – 60 cycles or \$4,500/wk)
- ✦ Matching Dual Team Bonus
- ✦ Travel Rewards(max – 300 points)
- ✦ Title Bonuses
- ✦ Activity Bonuses (4 levels)
- ✦ Dream Car Bonus

## Quest Travel Director

### Qualifications and Retention

- ✦ Be an Active QTA
- ✦ Have 4 Active PTA legs
- ✦ Have at least 16 active personally enrolled reps – 1 left and 1 right

### Eligible Commissions

- ✦ Direct sale commissions
- ✦ Fast Start Bonus
- ✦ Dual Team Bonus (max – 120 cycles or \$9,000/wk)
- ✦ Matching Dual Team Bonus
- ✦ Travel Rewards(max – 600 points)
- ✦ Title Bonuses
- ✦ Activity Bonuses (5 levels)
- ✦ Dream Car Bonus

## Diamond Travel Director

### Qualifications and Retention

- ✦ Be an Active QTA
- ✦ Have 4 Active QTD legs
- ✦ Have at least 24 active personally enrolled reps – 1 left and 1 right

### Eligible Commissions

- ✦ Direct sale commissions
- ✦ Fast Start Bonus
- ✦ Dual Team Bonus (max – 240 cycles or \$18,000/wk)
- ✦ Matching Dual Team Bonus
- ✦ Travel Rewards(max – 1,200 points)
- ✦ Title Bonuses
- ✦ Activity Bonuses (6 levels)
- ✦ Dream Car Bonus
- ✦ Diamond Director Bonus

## Quest Travel Advisor

### Qualifications and Retention

- ✦ Be an Active Independent Rep
- ✦ Purchase a QTA package OR accumulate 20 QPV by selling products

### Eligible Commissions

- ✦ Direct sale commissions
- ✦ Fast Start Bonus

## Silver Travel Advisor

### Qualifications and Retention

- ✦ Be an Active QTA
- ✦ Have 2 Active QTA legs
- ✦ Have at least 2 active personally enrolled reps – 1 left and 1 right

### Eligible Commissions

- ✦ Direct sale commissions
- ✦ Fast Start Bonus
- ✦ Dual Team Bonus (max – 15 cycles or \$1,125/wk)
- ✦ Matching Dual Team Bonus
- ✦ Travel Rewards(max – 75 pts)
- ✦ Title Bonuses
- ✦ Activity Bonuses (2 levels)

## Gold Travel Advisor

### Qualifications and Retention

- ✦ Be an Active QTA
- ✦ Have 3 Active STA legs
- ✦ Have at least 4 active personally enrolled reps – 1 left and 1 right

### Eligible Commissions

- ✦ Direct sale commissions
- ✦ Fast Start Bonus
- ✦ Dual Team Bonus (max – 30 cycles or \$2,250/wk)
- ✦ Matching Dual Team Bonus
- ✦ Travel Rewards(max – 150 points)
- ✦ Title Bonuses
- ✦ Activity Bonuses (3 levels)

To qualify, you simply become an IR (Independent Rep) and either purchase the QTA package or the CondoQuest package OR, sell 2 QTA packages or 5 CondoQuest Packages.

Income Disclaimer – Commissions and bonuses listed above are maximum limits of achievement based on title and are strictly based on personal performance.

\* The company will never pay more than 67% of the total weekly or monthly product revenue into the pay plan. This is to ensure the long term viability of the company.

\*\*No commissions are paid for recruiting. All commissions that go into the Independent Representatives commissions are strictly from product and membership sales. A product purchase is not required to become a Quest Travel Network Independent Rep.